



ECL HS-800/810 Series

Description

The **HS-800/810 Series** of quartz crystal oscillators provide MECL 10K and 10KH series compatible signals in industry standard four-pin DIP hermetic packages. Systems designers may now specify space-saving, cost-effective packaged ECL oscillators to meet their timing requirements.

Features

- Wide frequency range—15.0MHz to 250.0MHz
- User specified tolerance available
- Will withstand vapor phase temperatures of 253°C for 4 minutes maximum
- Space-saving alternative to discrete component oscillators
- High shock resistance, to 3000g
- All metal, resistance weld, hermetically sealed package
- Low Jitter
- MECL 10K and 10KH series compatible output on Pin 8
- High Q Crystal actively tuned oscillator circuit
- Power supply decoupling internal
- No internal PLL avoids cascading PLL problems
- High frequencies due to proprietary design
- Gold plated leads - Solder dipped leads available upon request
- RoHS Compliant, Lead Free Construction (unless solder dipped leads are supplied)
- COTS/Dual use

Electrical Connection

HS-800

Pin Connection

1	N.C.
7	V _{CC} /Ground
8	Output
14	V _{EE} -5.2V

HS-810

Pin Connection

1	N.C.
7	V _{EE} -5.2V
8	Output
14	V _{CC} /Ground

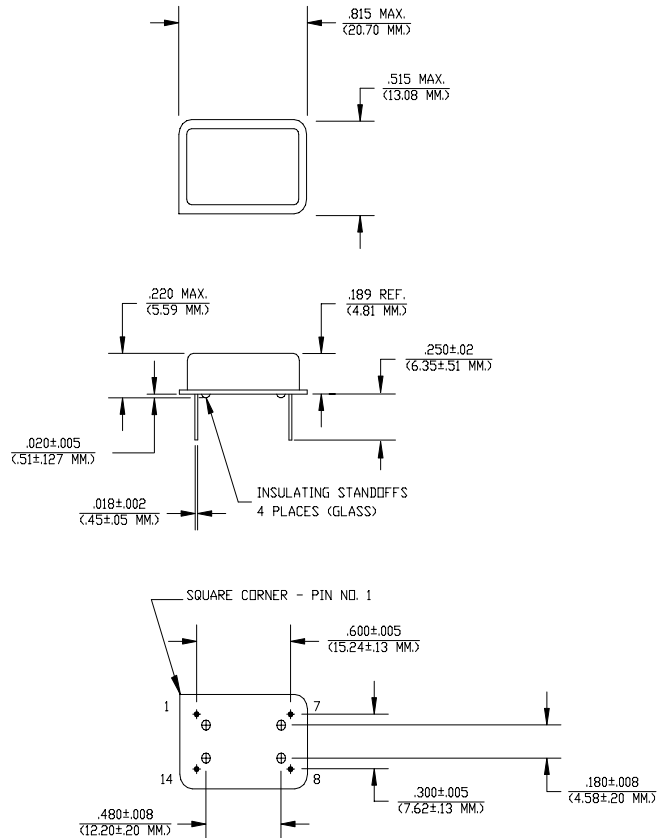

Dimensions are in inches and (MM)

HS-800/810 Series Continued
ECL

Rev. P

Operating Conditions and Output Characteristics

Electrical Characteristics

Parameter	Symbol	Conditions	Min	Typical	Max
Frequency	-----	-----	15.0MHz	-----	250.0MHz
Duty Cycle	-----	@ $V_{CC}-1.29V$	45/55%	-----	55/45%
Logic 0 ⁽²⁾	V_{OL}	-----	$V_{CC}-1.95V$	-----	$V_{CC}-1.60V$
Logic 1 ⁽²⁾	V_{OH}	-----	$V_{CC}-1.02V$	-----	$V_{CC}-0.74V$
Rise & Fall Time	tr,tf	20-80% V_O with 50 ohm load to $V_{CC}-2V$	-----	1.0 ns	1.5 ns
Jitter, RMS ⁽³⁾	-----	-----	-----	-----	5 psec
Frequency Stability ⁽¹⁾	dF/F	Overall conditions including: voltage, calibration, temp., 10 yr aging, shock, vibration	-100ppm	-----	+100ppm

General Characteristics

Parameter	Symbol	Conditions	Min	Typical	Max
Supply Voltage	V_{EE}	-----	-5.46V	-5.2V	-4.94V
Supply Current	I_{EE}	50 ohm termination To 2.00V below V_{CC}	0.0 mA	-----	80 mA
Output current	I_O	Low level Output Current	0.0 mA	-----	±50.0 mA
Operating temperature	T_A	-----	0°C	-----	70°C
Storage temperature	T_S	-----	-55°C	-----	125°C
Power Dissipation	P_D	-----	-----	-----	437 mW
Lead temperature	T_L	Soldering, 10 sec.	-----	-----	300°C
Load		50 Ohm to $V_{CC}-2V$ or Thevenin Equivalent, Bias Required			
Start-up time	t_s	-----	-----	2 ms	10 ms

Environmental and Mechanical Characteristics

Mechanical Shock	Per MIL-STD-202, Method 213, Condition E
Thermal Shock	Per MIL-STD-883, Method 1011, Condition A
Vibration	0.060" double amplitude 10 Hz to 55 Hz, 35g's 55Hz to 2000 Hz
Soldering Condition	300°C for 10 seconds
Hermetic Seal	Leak rate less than 1×10^{-8} atm.cc/sec of helium
ESD Sensitivity	Human Body Model per ON Semiconductor 10kH series ECL: 500V min.

Footnotes:

- Standard frequency stability ($\pm 20, \pm 25, \pm 50$ ppm & others available)
- V_{OL}, V_{OH} , referenced to ground (V_{CC}) with $V_{EE} = -5.2V$
- Jitter performance is frequency dependent. Please contact factory for full characterization.
RMS jitter bandwidth of 12kHz to 20MHz.

Creating a Part Number	
HS - A80X - FREQ	
Package Code	Tolerance/Performance
HS Leaded 4 pin (14 pin)	0 ±100ppm 0-70°C
SM Leaded 4 pin (14 pin) SMD	1 ±50ppm 0-70°C
Gull Wing	7 ±25ppm 0-70°C
Input Voltage	9 Customer Specific
Code Specification	A ±20ppm 0-70°C
A 3.3V	B ±50ppm -40 to +85°C
5V	C ±100ppm -40 to +85°C

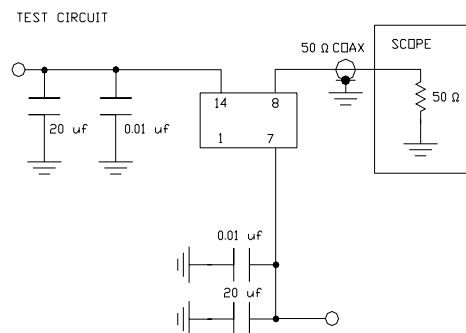

TEST CIRCUIT USES A SPLIT SUPPLY OF +2V AND -3.2V FOR EASE OF TESTING.